



AIR CONDITIONING



REFRIGERATION



HEATING



# hi-capacity

## CONDENSATE REMOVAL PUMP

This high efficiency boiler pump offers unsurpassed performance and is ideal for commercial boiler applications.



288L/h max. flow



5m max. rec. head (flow rate 10L/h)

### KEY FEATURES

- Easy access tank
- Twist & click non return outlet barb
- Built-in spirit level
- Plug & play

### SUITABILITY

- Up to 200kW / 682,000Btu/h with condensate PH value >2.7
- ✓ **Perfect for...** Larger domestic commercial gas & oil fired condensing boilers

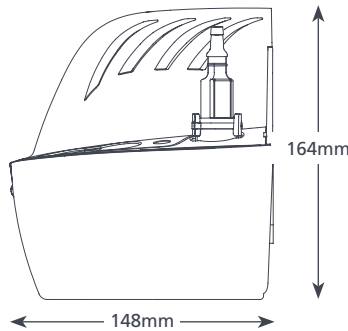
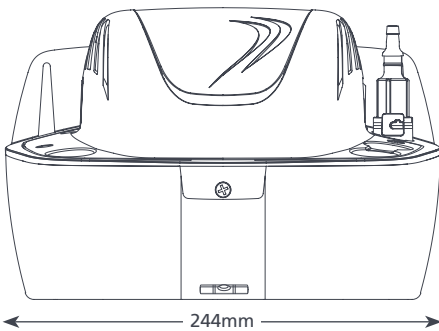

### HI-CAPACITY SPECIFICATIONS

Max. flow	288L/h @ 0 head
Max. rec. head	5m
Tank capacity	2L
Sound level@1m	60dB(A)
Power supply	230 VAC, 0.6A, 50Hz
Rated	Non continuous
Class	I appliance
Max. unit output	200kW / 682,000 Btu/h
Max. water temp	60°C / 140°F
Inlet/outlet	x3 25mm in, 6-10mm out
IP Protection	IP20
Safety switch	3.0A Normally closed
Thermal protection	✓
Fully potted	n/a
Self priming	n/a

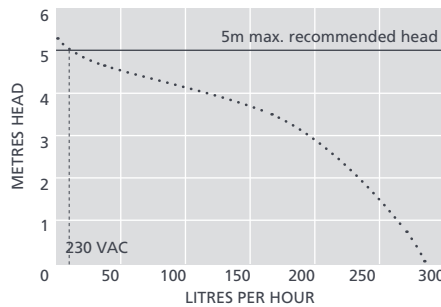

### HI-CAPACITY OPTIONS

Hi-Capacity (UK)	FP2952/2
Hi-Capacity (EU)	FP2951/2

### IN THE BOX

Hi-Capacity boiler pump • 2m Plug & play power cable • 6m discharge tube (10mm ID) • Pipe adaptor • Fixing kit • Install manual

### SUGGESTED XTRA ACCESSORIES

Description	Part No.
Tube To Soil Stack Adaptor	FP2038
1 Amp Fuse	FP2620
Vinyl Tube Braided 1/4" (6mm)	AX5100
Vinyl Tube Braided 3/8" (10mm)	AX5101
Acid Neutraliser	FP1021



For more installation accessories take a look at our Aspen Xtra range

Download manual at [aspenspumps.com](http://aspenspumps.com)

Information correct at time of going to press.