

5. Electrical Part

5.1 Wiring Diagram

● Instruction

Symbol	Symbol Color	Symbol	Symbol Color	Symbol	Name
WH	White	GN	Green	CAP	Jumper cap
YE	Yellow	BN	Brown	COMP	Compressor
RD	Red	BU	Blue		Grounding wire
YEGN	Yellow/Green	BK	Black	/	/
VT	Violet	OG	Orange	/	/

Note: Jumper cap is used to determine fan speed and the swing angle of horizontal lover for this model.

● Indoor Unit

GWH09MA-K3DNA3L/I GWH09MA-K3DNA4L/I GWH09MA-K3DNB7L/I GWH09MA-K3DND3L/I GWH09MA-K3DNC9L/I
 GWH09MA-K3DNB3L/I GWH09MA-K3DNC8L/I GWH09MA-K3DNA9L/I GWH09MA-K3DNE2L/I GWH09MA-K3DNA8L/I
 GWH09MA-K3DNC5L/I GWH09MA-K3DNA2L/I GWH12MA-K3DNC5L/I GWH12MA-K3DNA2L/I GWH12MA-K3DNA3L/I
 GWH12MA-K3DNC8L/I GWH12MA-K3DNB7L/I GWH12MA-K3DNC9L/I GWH12MA-K3DND3L/I GWH12MA-K3DNB3L/I
 GWH12MA-K3DNA9L/I GWH12MA-K3DNE2L/I GWH12MA-K3DNA8L/I GWH09MA-K3DNA5L/I GWH12MA-K3DNA5L/I
 GWH12MA-K3DNA4L/I GWH09MA-K3DNC2L/I GWH12MA-K3DNC2L/I GWH09MA-K3DNC1L/I GWH12MA-K3DNC1L/I
 GWH09MA-K3DNA3M/I GWH12MA-K3DNA3M/I

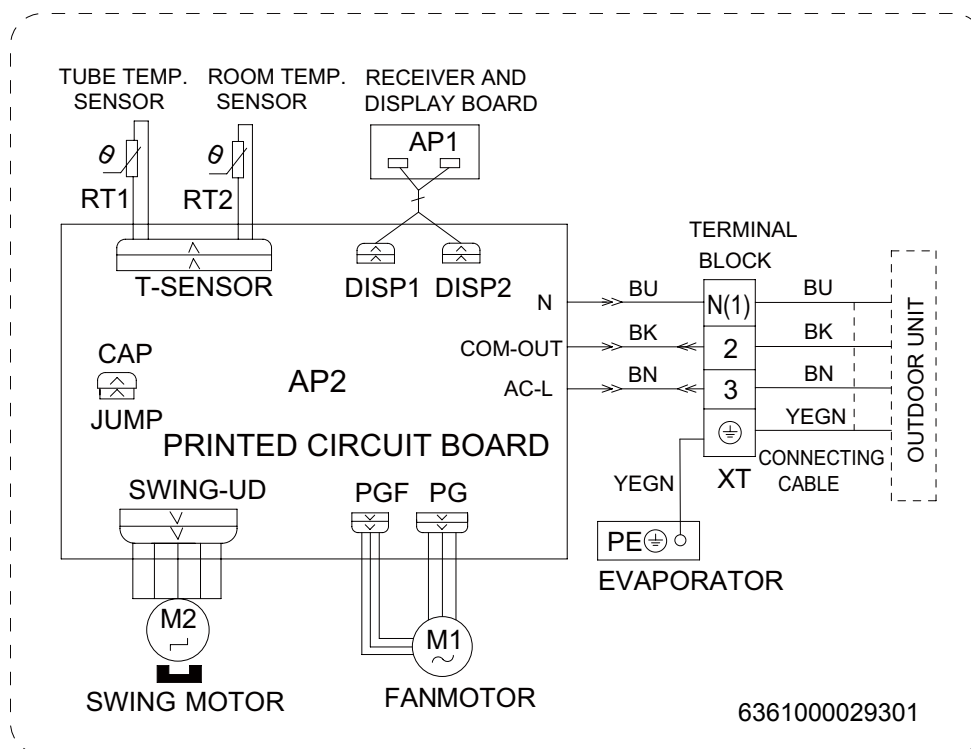

GWH09MA-K3DNC4L/I
GWH12MA-K3DNC4L/I

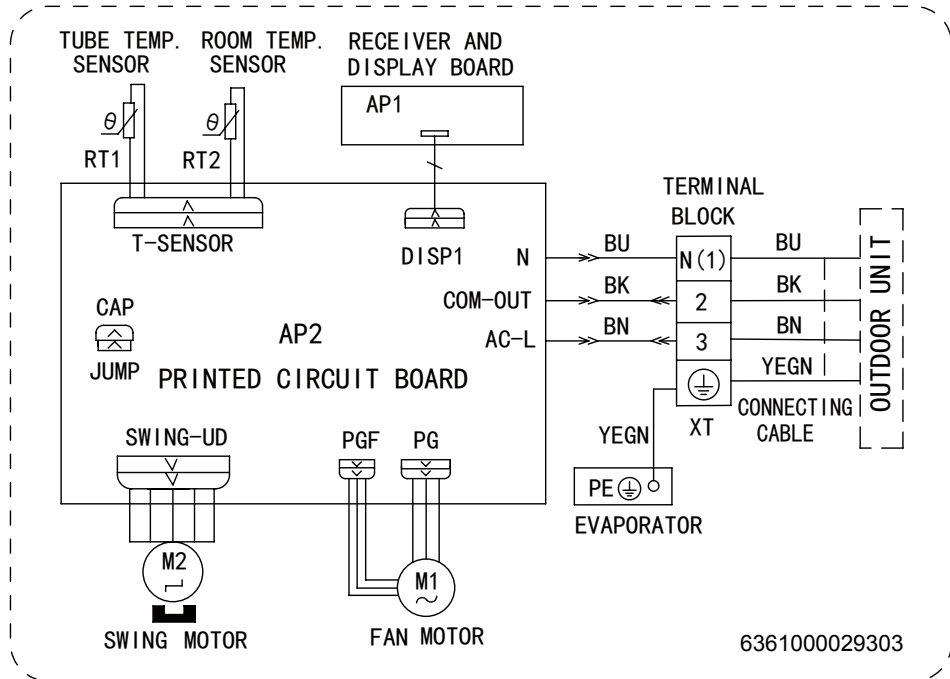

• Outdoor Unit

GWH09MA-K3DNA3L/O
GWH09MA-K3DNA3M/O

